

**DOWN
UNDER**



JUNIOR MOWERS

DRIVERS HANDBOOK

For more info visit:

www.downundermtpa.com.au



Down Under MTPA

©Copyright 2019

Down Under Modified Tractor Pulling Association Inc.

Incorporated in Victoria, A0102608Q

ABN: 17 457 288 085

www.downundermtpa.com.au

This document is ©Copyright. Apart from any fair dealing for the purposes of private study, research, criticism or review as permitted under the Copyright Act, no part may be reproduced by any process without the express permission of the **Down Under Modified Tractor Pulling Association Inc.**

All enquiries should be addressed to Kevin Carne (Contact details on page 11).

The **Down Under MTPA** believe all the information supplied within this document to be true and correct at time of printing. They are not, however, in a position to make a guarantee to this effect and accept no liability in the event of any information proving inaccurate.

While every effort has been made to ensure complete accuracy, the **Down Under MTPA** cannot be held responsible for any error and / or omissions. The **Down Under MTPA** is strongly focused on safety within the sport of Tractor Pulling and trust that in all cases common sense will prevail.

This document will change from time to time and the **Down Under MTPA** will make all alterations / updates available via the **Down Under MTPA** Secretary.

THIS IS A CONTROLLED DOCUMENT

Document Created - August 8, 2019

CONTENTS

1	DRIVER CONDUCT	4
<hr/>		
2	GENERAL RULES	5
<hr/>		
2.1	Chassis	5
2.2	Engine	5
2.3	Engine Shielding	5
2.4	Driveline	5
2.5	Throttle	5
2.6	Exhaust	5
2.7	Tyres	5
2.8	Batteries	5
2.9	Fuel	5
2.10	Weight	5
3	SAFETY RULES	6
<hr/>		
3.1	Roll Cage	6
3.2	Seat	6
3.3	Drawbar	6
3.4	Wheelie bars	8
3.5	Kill Switch	8
3.6	Fire Extinguisher	8
3.7	Driver Suits	8
3.8	Scrutineers	8
3.9	Age	8
4	MOWER / DRIVER REGISTRATION	9
<hr/>		
5	WORKING WITH CHILDREN CHECK	10
<hr/>		

1 DRIVER CONDUCT

1. Before a mower can enter the track area, the driver must be suited up, helmet on and ready to pull.
2. All drivers must be able to operate the mower in a safe manner, be able to stop forward and reverse motion at any time without assistance from your crew members.
3. When hooking and unhooking from the sled, you must remain seated at all times on the mower. Once you have backed up to the sled, you must put your mower out of gear, put your foot on the brake and hold both hands in the air.
4. Once this is done, the Clerk of the Course / Hooker will know it's safe to go behind the mower and hook up without being run / mowed over.
5. Once the sled is hooked to the mower, you must wait to get a green flag from the Clerk of the Course / Flagman. Once the green flag is shown, take up the slack in the chain to make sure it's tight before you drive off. When the slack has been taken up, you can commence your pull.
6. If, for some reason the Clerk of the Course / Flagman gives you a red flag during your pull, you must **STOP** immediately, remain seated, put your mower out of gear, apply brakes and raise both hands in the air, then await instructions as to why you've received a red flag.
7. Again at the end of your pull, you will need to back up a little to unhook the sled and raise both your hands as before.
8. Under no circumstances is there to be any speeding off the track and / or around the pit area (walking pace only).
9. There is to be only one (1) person on the mower at any time.
ABSOLUTELY NO PASSENGERS.
10. No mower is to be left unattended while the engine is running, driver must be seated while mower is in operation.
11. Once your mower event is over. You will not be allowed back into the **HOT ZONE** as per normal competition rules during the day.
- 12. ALL PARENTS MUST SUPERVISE THEIR CHILDREN WHILE DRIVING IN THE PITS & IN THE HOT ZONE. NO PARENTS PRESENT, YOUR CHILD WON'T BE ALLOWED TO DRIVE. PARENTS WILL NEED TO BE DOWN UNDER MTPA MEMBERS.**

2 GENERAL RULES

2.1 Chassis

Original mower chassis MUST be used. Cutting deck and drive pulleys removed. Bonnet to correspond with make of mower (allowed to change colour). Mower to be a maximum of 6ft long, end to end, and 4ft wide.

2.2 Engine

- Any single or twin cylinder 4 stroke vertical crank engine from lawn and garden industry origin
- A maximum of 16 H/P for a single cylinder or 500 cc for a twin

STRICTLY NO OUTBOARD OR MARINE TYPE ENGINES TO BE USED.

2.3 Engine Shielding

Panels are to be fitted to bonnet or chassis to fully enclose engine compartment.

An expanded steel mesh with a maximum hole of 3mm will be allowed, as long as it is secured on all four sides to prevent it from blowing off, in the event of an explosion.

Shielding must cover from the bonnet all the way down to the chassis. The bonnet must be bolted / latched down during the competition.

2.4 Driveline

Driveline must be belt driven from the engine to the first part of the drive, whether it is a standard drive or a homemade drive (eg: hydraulic).

2.5 Throttle

Throttle can be hand and / or foot operated, but must return to idle when released.

2.6 Exhaust

Exhaust must be vertical, with a minimum of 12 inches above the last bend.

2.7 Tyres

Tyre size to be a maximum of 24 x 12 x 10 inches or the equivalent in metric.

2.8 Batteries

- Mowers using acid type batteries must have a battery cover
- Mowers using gel type batteries don't need a cover
- All Batteries must be securely fastened

2.9 Fuel

Legal fuels are pump fuels:

- Unleaded
- Premium Unleaded

2.10 Weight

The maximum weight of all the mowers is to be no more than 250kg, without the driver. The mowers will be weighed at each event, before the competition begins.

3 SAFETY RULES

3.1 Roll Cage

Roll cage to be made out of a minimum of **1 inch black structural steel pipe or 1 ½ inch x 3mm aluminium pipe, (NO EXHAUST TUBE ALLOWED).**

Cage to have **2 main vertical loops**, one piece side to side, with a minimum spacing of 150mm or 6 inches centre to centre or a maximum of 250mm or 10 inches centre to centre **(see Diagram One).**

One rear loop in centre to tie front and rear vertical loops together. One horizontal tie loop between all loops from side to side at shoulder height. Rear loop may finish at the horizontal tie loop or continue through to the bottom of the cage.

Roll cage to have **4 mounting bolts per side, minimum 3/8th H/T.** Cage must not be mounted to drawbar.

ROLL CAGE MUST BE ABLE TO LIFT THE ENTIRE MOWER OFF THE GROUND USING EITHER ONE OF THE VERTICAL LOOPS.

3.1.1 Diagram One: Roll Cage Construction

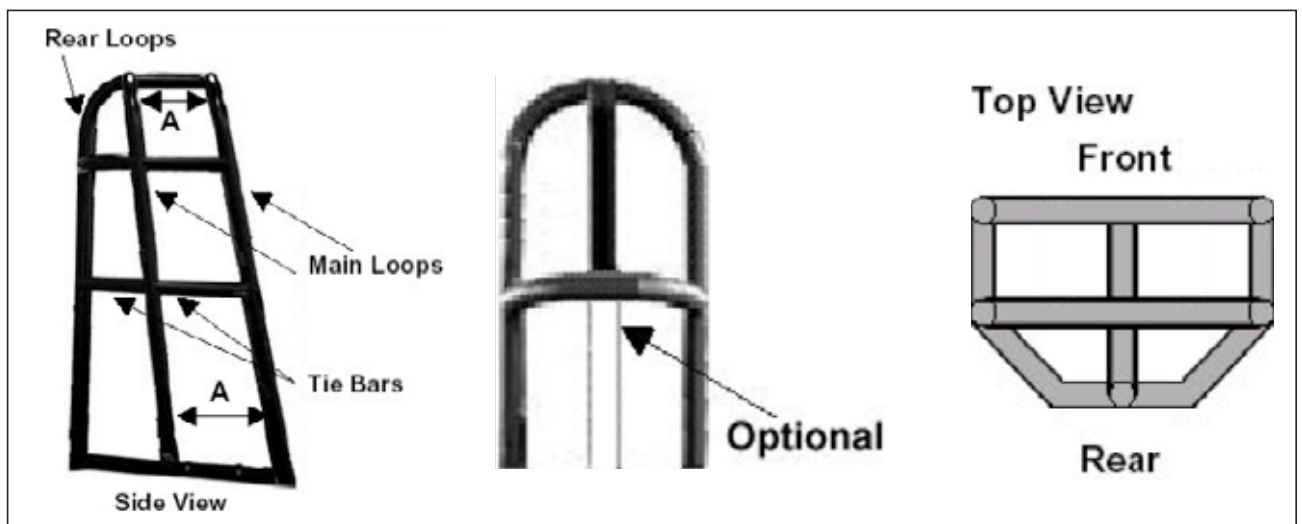

3.2 Seat

Seat and a 4 point harness must be mounted to the roll cage. Flip type seats must be secured at the top of seat to avoid flipping while in competition.

3.3 Drawbar

Drawbar is to be mounted a minimum of **250mm or 10 inches** along both sides of the chassis with a minimum of **two 3/8th H/T bolts per side, no less than 150mm or 6 inches** apart.

Drawbar must have a **50mm x 50mm x 3mm** flat backing plate on the other side of the chassis from the drawbar plate.

Drawbar hook point to be a maximum of **250mm or 10 inches** off the ground and not extend beyond rear of back tyres.

For drawbar specifications:

See Diagrams Two, Three & Four.

3.3.1 Diagram Two: Drawbar Construction

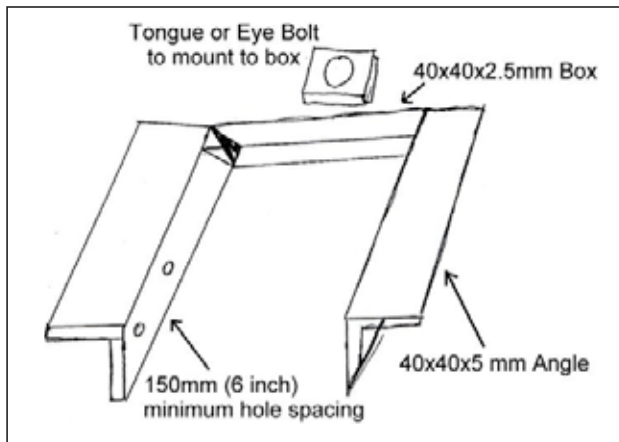

3.3.2 Diagram Three: Drawbar Construction

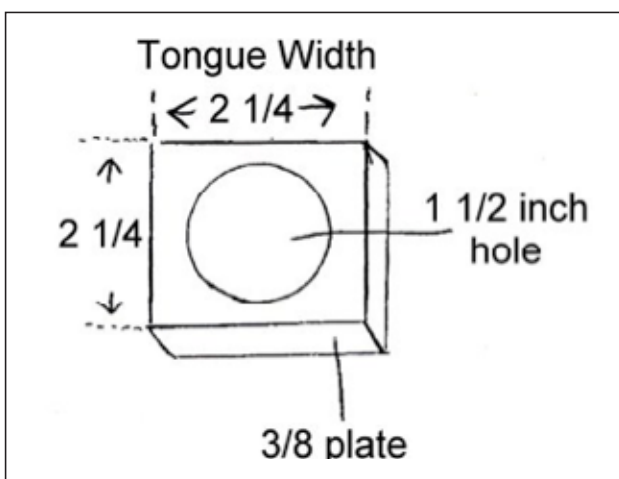

3.3.3 Diagram Four: Drawbar Construction

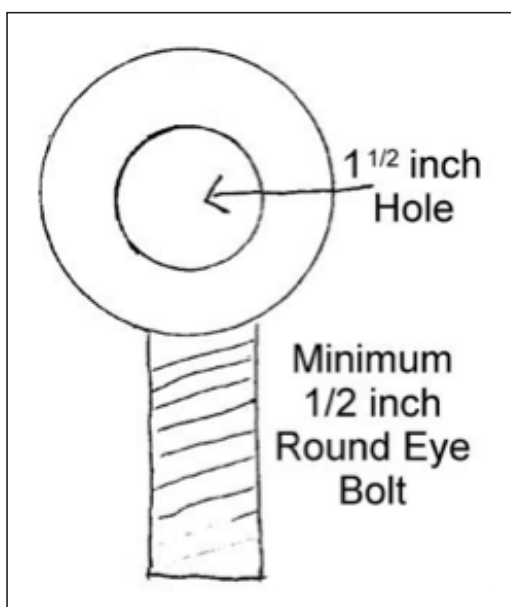

3.4 Wheelie bars

Stabiliser bars are to be mounted to both sides of the chassis. Bars must be a minimum of 4 inches behind the rear of the back tyre and must be no more than 3 inches off the ground with a 2 inch square skid pad.

Stabiliser bars must be able to support the entire weight of the mower. Stabiliser bars must not be mounted to the drawbar.

3.5 Kill Switch

All mowers are to have a kill switch plug with a 2 inch lead loop. The switch is to be mounted 3ft off the ground in centre rear of the mower. The kill switch must stop the engine (and electric fuel pump, if fitted) when plug is removed.

3.6 Fire Extinguisher

To be a minimum of ½ kg dry chemical and mounted on the mower.

3.7 Driver Suits

Suits must be wrist to ankle overalls, leather rigging gloves, leather work boots and a full face helmet must be worn while competing.

3.8 Scrutineers

There will be Scrutineers (who have been schooled on the Down Under Juniors Mower Rules) that will check and enforce all these rules and regulations at every event. **The scrutineers decision is final on the day.**

3.9 Age

Drivers are to be aged between 8 and 14 years. All new drivers must complete a proficiency test before being allowed to run. All drivers must be supervised by an adult.

4 MOWER / DRIVER REGISTRATION

Membership Type	Cost	Includes
Mower Registration	\$20	Per mower / per year (includes Drivers handbook & tags)
Driver Registration	\$20	Per driver / per year
AASA Junior Extreme Licence	\$35	To be purchased annually from: https://aasa.com.au/licences/annual-licences/

Competitors are required to take photos of their mowers and send them to **Down Under Junior Mowers**. (Photos of two sides, front & back). These will be kept in your Drivers Handbook.

5 WORKING WITH CHILDREN CHECK

A Working with Children Check is required to help / volunteer with **Down Under Junior Mowers**.

The Working with Children Check is a screening process for assessing or re-assessing people who work with or care for children in Victoria.

We take a detailed look at the criminal history, and relevant professional conduct findings of applicants to ensure we're assisting to protect children from sexual or physical harm.

To apply for a Working with Children Check visit:

www.workingwithchildren.vic.gov.au

